

THIS DRAWING IS UNPUBLISHED. VERTRAULICHE UNVERÖFFENTLICHTE ZEICHNUNG. RELEASED FOR PUBLICATION. FREI FÜR VERÖFFENTLICHUNG. 1993. MATED WITH: PASSEND ZU: -

© COPYRIGHT 1993 BY AMP INCORPORATED. ALLE RECHTE VORBEHALTEN.

LOC	DIST	REVISIONS			DATE	DWN	APVD
AI	-	P	LTR	ANDERUNGEN			
PROJEKT NR.:				DESCRIPTION			
-				BESCHREIBUNG			
				REVISION PER E600-2081-00 (TEXT TO ENGLISH TRANSLATED)	06-SEP-00	R.5.	G.F.

ORDER NO. BESTELL-NR.	CROSS SECTION QUERSCHNITT		STRIP LENGTH ABISOLIER-LÄNGE	TYPE AUSFÜHRUNG	COLOUR FARBE	l <sub>1</sub> /mm	l <sub>2</sub> /mm	d <sub>1</sub> /mm	s <sub>1</sub> /mm	d <sub>2</sub> /mm	s <sub>2</sub> /mm	PACKING UNIT VERPACKUNGSEINHEIT PARTS/STÜCK BAG/BEUTEL
	mm <sup>2</sup>	AWG										
966 067-1	0.50	20	8	SHORT KURZ	WHITE WEIß	12.0 ±1.5	6.0 ±0.4	1.0 +0.14	0.15 ±0.05	2.6 ±0.2	0.25 ±0.10	500
966 067-2	0.50	20	10	NORMAL NORMAL	WHITE WEIß	14.0 ±1.5	8.0 ±0.4	1.0 +0.14	0.15 ±0.05	2.6 ±0.2	0.25 ±0.10	500
966 067-3	0.50	20	12	HALFLONG HALBLANG	WHITE WEIß	16.0 ±1.5	10.0 ±0.4	1.0 +0.14	0.15 ±0.05	2.6 ±0.2	0.25 ±0.10	500
966 067-4	0.75	18	8	SHORT KURZ	GREY GRAU	12.0 ±1.5	6.0 ±0.4	1.2 +0.14	0.15 ±0.05	2.8 ±0.2	0.25 ±0.10	500
966 067-5	0.75	18	10	NORMAL NORMAL	GREY GRAU	14.0 ±1.5	8.0 ±0.4	1.2 +0.14	0.15 ±0.05	2.8 ±0.2	0.25 ±0.10	500
966 067-6	0.75	18	12	HALFLONG HALBLANG	GREY GRAU	16.0 ±1.5	10.0 ±0.4	1.2 +0.14	0.15 ±0.05	2.8 ±0.2	0.25 ±0.10	500
966 067-7	0.75	18	14	LONG LANG	GREY GRAU	18.0 ±1.5	12.0 ±0.6	1.2 +0.14	0.15 ±0.05	2.8 ±0.2	0.25 ±0.10	500
966 067-8	1.00	17	8	SHORT KURZ	RED ROT	12.0 ±1.5	6.0 ±0.4	1.4 +0.14	0.15 ±0.05	3.0 ±0.2	0.25 ±0.10	500
966 067-9	1.00	17	10	NORMAL NORMAL	RED ROT	14.0 ±1.5	8.0 ±0.4	1.4 +0.14	0.15 ±0.05	3.0 ±0.2	0.25 ±0.10	500
1-966 067-0	1.00	17	12	HALFLONG HALBLANG	RED ROT	16.0 ±1.5	10.0 ±0.4	1.4 +0.14	0.15 ±0.05	3.0 ±0.2	0.25 ±0.10	500
1-966 067-1	1.00	17	14	LONG LANG	RED ROT	18.0 ±1.5	12.0 ±0.6	1.4 +0.14	0.15 ±0.05	3.0 ±0.2	0.25 ±0.10	500
1-966 067-2	1.50	16	10	NORMAL NORMAL	BLACK SCHWARZ	14.0 ±1.5	8.0 ±0.4	1.7 +0.25	0.15 ±0.05	3.5 ±0.2	0.25 ±0.10	500
1-966 067-3	1.50	16	12	HALFLONG HALBLANG	BLACK SCHWARZ	16.0 ±1.5	10.0 ±0.4	1.7 +0.25	0.15 ±0.05	3.5 ±0.2	0.25 ±0.10	500
1-966 067-4	1.50	16	14	HALFLONG+ HALBLANG+	BLACK SCHWARZ	18.0 ±1.5	12.0 ±0.6	1.7 +0.25	0.15 ±0.05	3.5 ±0.2	0.25 ±0.10	500
1-966 067-5	1.50	16	20	LONG LANG	BLACK SCHWARZ	24.0 ±2.0	18.0 ±0.6	1.7 +0.25	0.15 ±0.05	3.5 ±0.2	0.25 ±0.10	500
1-966 067-6	2.50	14	10	NORMAL NORMAL	BLUE BLAU	14.0 ±1.5	8.0 ±0.4	2.2 +0.25	0.15 ±0.05	4.2 ±0.2	0.25 ±0.10	500
1-966 067-7	2.50	14	14	HALFLONG HALBLANG	BLUE BLAU	18.0 ±1.5	12.0 ±0.6	2.2 +0.25	0.15 ±0.05	4.2 ±0.2	0.25 ±0.10	500
1-966 067-8	2.50	14	20	LONG LANG	BLUE BLAU	24.0 ±2.0	18.0 ±0.6	2.2 +0.25	0.15 ±0.05	4.2 ±0.2	0.25 ±0.10	500
1-966 067-9	4.00	11	12	NORMAL NORMAL	GREY GRAU	17.0 ±1.5	10.0 ±0.4	2.8 +0.25	0.20 ±0.05	4.8 ±0.4	0.30 ±0.10	500
2-966 067-0	4.00	11	14	HALFLONG HALBLANG	GREY GRAU	20.0 ±1.5	12.0 ±0.6	2.8 +0.25	0.20 ±0.05	4.8 ±0.4	0.30 ±0.10	500
2-966 067-1	4.00	11	20	LONG LANG	GREY GRAU	26.0 ±2.0	18.0 ±0.6	2.8 +0.25	0.20 ±0.05	4.8 ±0.4	0.30 ±0.10	100
2-966 067-2	6.00	10	14	NORMAL NORMAL	YELLOW GELB	20.0 ±1.5	12.0 ±0.6	3.5 +0.30	0.20 ±0.05	6.3 ±0.4	0.30 ±0.10	100
2-966 067-3	6.00	10	20	LONG LANG	YELLOW GELB	26.0 ±2.0	18.0 ±0.6	3.5 +0.30	0.20 ±0.05	6.3 ±0.4	0.30 ±0.10	100
2-966 067-4	10.00	7	15	NORMAL NORMAL	RED ROT	22.0 ±2.0	12.0 ±0.6	4.5 +0.30	0.20 ±0.05	7.6 ±0.4	0.40 ±0.15	100
2-966 067-5	10.00	7	21	LONG LANG	RED ROT	28.0 ±2.0	18.0 ±0.6	4.5 +0.30	0.20 ±0.05	7.6 ±0.4	0.40 ±0.15	100
2-966 067-6	16.00	5	15	NORMAL NORMAL	BLUE BLAU	24.0 ±2.0	12.0 ±0.6	5.8 +0.30	0.20 ±0.05	8.8 ±0.4	0.40 ±0.15	100
2-966 067-7	16.00	5	21	LONG LANG	BLUE BLAU	28.0 ±2.0	18.0 ±0.6	5.8 +0.30	0.20 ±0.05	8.8 ±0.4	0.40 ±0.15	100
2-966 067-8	25.00	3	19	NORMAL NORMAL	YELLOW GELB	30.0 ±2.0	16.0 ±0.6	7.3 +0.40	0.20 ±0.05	11.2 ±0.5	0.40 ±0.15	50
2-966 067-9	25.00	3	21	HALFLONG HALBLANG	YELLOW GELB	30.0 ±2.0	18.0 ±0.6	7.3 +0.40	0.20 ±0.05	11.2 ±0.5	0.40 ±0.15	50
3-966 067-0	25.00	3	24	LONG LANG	YELLOW GELB	36.0 ±2.0	22.0 ±0.6	7.3 +0.40	0.20 ±0.05	11.2 ±0.5	0.40 ±0.15	50
3-966 067-1	35.00	2	19	NORMAL NORMAL	RED ROT	30.0 ±2.0	16.0 ±0.6	8.3 +0.40	0.20 ±0.05	12.7 ±0.5	0.40 ±0.15	50
3-966 067-2	35.00	2	21	HALFLONG HALBLANG	RED ROT	30.0 ±2.0	18.0 ±0.6	8.3 +0.40	0.20 ±0.05	12.7 ±0.5	0.40 ±0.15	50
3-966 067-3	35.00	2	28	LONG LANG	RED ROT	39.0 ±2.0	25.0 ±0.6	8.3 +0.40	0.20 ±0.05	12.7 ±0.5	0.40 ±0.15	50
3-966 067-4	50.00	-	25	NORMAL NORMAL	BLUE BLAU	36.0 ±2.0	20.0 ±0.6	10.3 +0.40	0.30 ±0.05	15.0 ±1.0	0.50 ±0.15	50
3-966 067-5	50.00	-	30	LONG LANG	BLUE BLAU	40.0 ±2.0	25.0 ±0.6	10.3 +0.40	0.30 ±0.05	15.0 ±1.0	0.50 ±0.15	50

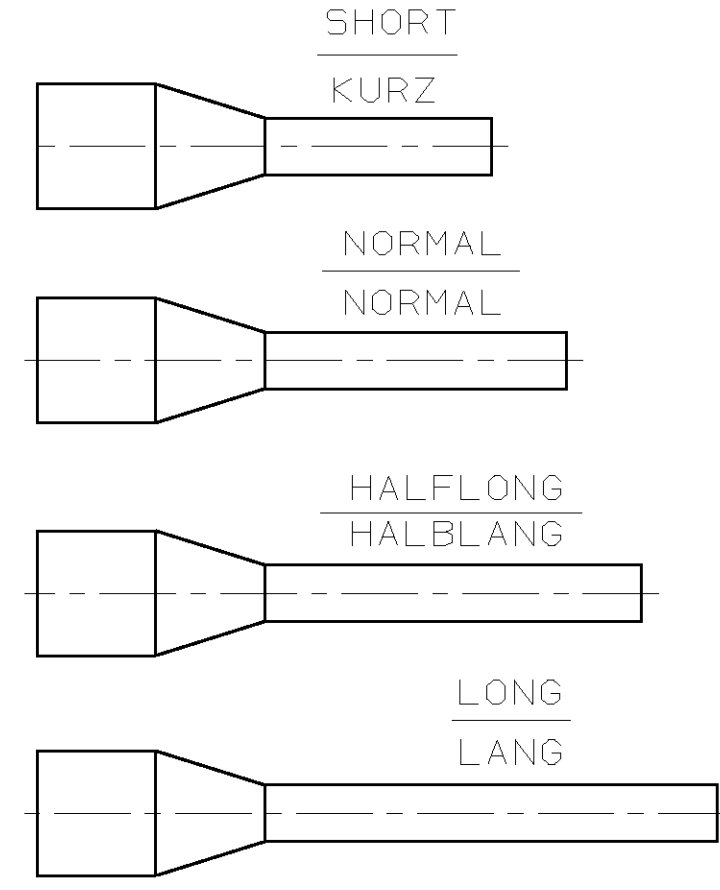
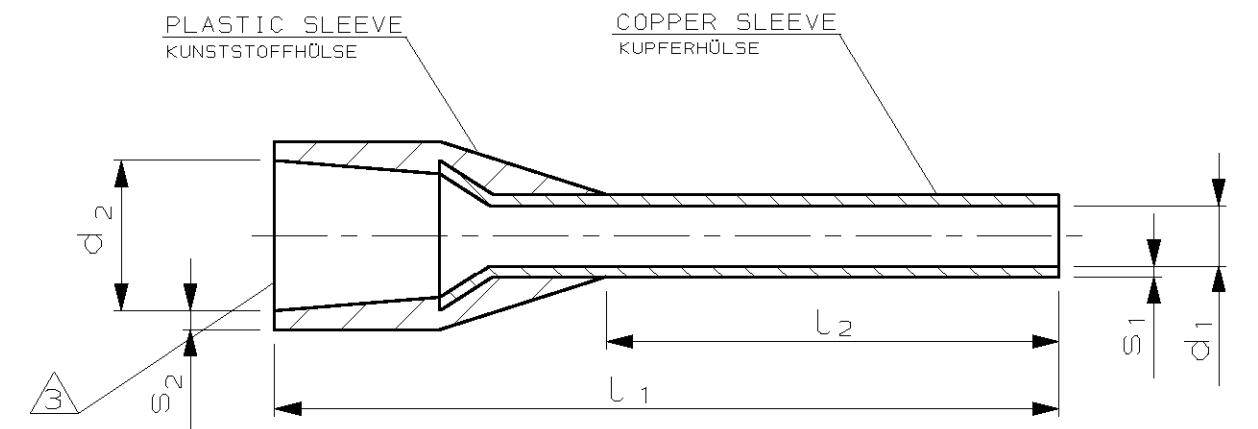

- ⚠ THE AWG CROSS-SECTION CAN SLIGHT DEVIATING OF THE DIN-STANDARD CROSS-SECTION VALUES
- ⚠ DER AWG-QUERSCHNITT KANN VON DEN DIN-NORM QUERSCHNITTSWERTEN GERINGFÜGIG ABWEICHEN.
- ⚠ RECOMMENDED STRIP LENGTH
- ⚠ EMPFOHLENE ABISOLIERLÄNGE
- ⚠ MAX. INSULATION-DIA. OF WIRE: d<sub>2</sub>MIN.- 0.1
- ⚠ MAX. ISOLATIONS-Ø DER LEITUNG: d<sub>2</sub>MIN.- 0.1
- ⚠ TUBULAR END-SLEEVE WITH PLASTIC SLEEVE ACCORDING TO DIN 46228 PART 4
- ⚠ ADERENDHÜLSE MIT KUNSTSTOFFHÜLSE NACH DIN 46228 TEIL 4

+ SPECIAL

+ SPEZIAL

THIS DRAWING IS A CONTROLLED DOCUMENT FOR AMP INCORPORATED. IT IS SUBJECT TO CHANGE AND THE CONTROLLING ENGINEERING ORGANIZATION SHOULD BE CONTACTED FOR THE LATEST REVISION. DIESSES ZEICHNUNGSDOKUMENT WIRD DURCH AMP INCORPORATED KONTROLLIERT. ÄNDERUNGEN, DIE DEM TECHNISCHEN FORTSCHRITT DIENEN, SIND VORBEHALTEN. DEN NEUELLS LETZTBESTEHENDEN ÄNDERUNGSSTAND ERFAHREN SIE AUF ANFRAGE.		DWN R. Schmidt 14-NOV-96	tyco Electronics AMP GmbH D - 64625 Bensheim	
DIMENSIONS: mm		CHK W. Böck 14-NOV-96	AMP	
OTHERWISE SPECIFIED: ALLGEMEINTOLERANZEN n. ISO 8015 n. ISO 2768 - mH - E n. DIN 16901 - 140		APVD G.FELDMEIER 12-SEP-00	TUBULAR END SLEEVE WITH PLASTIC SLEEVE ADERENDHÜLSE MIT KUNSTSTOFFHÜLSE	
MATERIAL PP/E-Cu		PRODUCT SPEC VERARBEITUNGSSPEZ.	SIZE A2	RESTRICTED TO NUR FÜR
FINISH/OBERFLÄCHE/FARBE S <sub>n</sub> SEE TABLE		APPLICATION SPEC WEIGHT GEWICHT	DRAWING NO. ZEICHNUNGS-NR. G-966067	REV B1
CUSTOMER DRAWING		MASSSTAB	BLATT 1 OF 1	